

EXT type seal – flanged type, extended diaphragm

Design description

The EXT construction has a seal body that is made of a (forged) blind flange. The weld of the diaphragm to the seal body is a wetted part and therefore diaphragm materials are mostly chosen the same as the flange material. The EXT is typically used in combination with (differential) pressure transmitters for applications such as level, flow and (absolute) pressure measurement.

Flange diaphragm combinations

The diaphragm is TIG-welded to the flange and is designed to have the best performance for the specific size. This means that the flexibility and shape is carefully tested and measured. The standard thickness of diaphragm foil is 0.075mm



Flange Material	Diaphragm material		
	General name	UNS	Wst.
AISI 316(L)	AISI 316L	S31603	1.4404
	AISI 304L	S30400	1.4306
	AISI 321	S32100	1.4541
	AISI 316 UG	S31603	1.4435
	Alloy C276	N27600	2.4810
AISI 304L	AISI 304L	S30400	1.4306
AISI 310 MoLn	25-22-2 LMN	S31050	1.4466
AISI 316 UG	AISI 316 UG	S31600	1.4435
AISI 321	AISI 321	S32100	1.4541
AISI 904(L)	AISI 904L	N08904	1.4539
Alloy 20	Alloy 20	N08020	2.4660
Alloy 400	Alloy 400	N04400	2.4360
Alloy 600	Alloy 600	N06600	2.4816
Alloy 625	Alloy 625	N06625	2.4856
Alloy 825	Alloy 825	N08825	2.4858
Alloy B2	Alloy B2	N10665	2.4617
Alloy C-22	Alloy C-22	N06022	2.4602
Alloy C-276	Alloy C-276	N10276	2.4810
Duplex F44	254 SMO (6Mo)	S31254	1.4547
Duplex F51/F60	Duplex 2205	S32205	1.4462
Duplex F53	Super Duplex 2507	S32750	1.4410
Duplex F55	Super Duplex 2507	S32750	1.4410
Nickel 201	Nickel 201	N02201	2.4068
Titanium Gr. 2	Titanium Gr. 1	R50250	2.7025
Zirconium 702	Zirconium 702	R60702	-

Flange size, rating and facings - ASME B16.5

ASME B16.5			
Size	Rating	Facing	Roughness
1" to 4"	cl. 150 - cl. 2500	RF, LMF, FF, SGF	Ra 3.2-6.3 µm
		RJF, SFF	Ra <1.6 µm
		SMF, LTF, STF, LGF, LFF	Ra <3.2 µm

Flange size, rating and facings - EN 1092-1

EN 1092-1			
Size	Rating	Type	Roughness
DN20 to DN100	PN10-400	A, B1, E, F	Ra 3.2-12.5 µm
		B2, C, D, G, H	Ra <0.8-3.2 µm

Gold coatings

Several types of gold coating can be applied on the seals. The selection possibilities are:

- 25 µm Hydrogen protection (diaphragm only)
- 40 µm Hydrogen protection (diaphragm only)

-> See datasheet "Gold coatings"

Polymer coatings & lining

Polymer coatings come in several types. The technical data on thickness and temperature limitation can be found in datasheet "polymer solutions" The applicable selection on EXT seals are:

- PTFE coating
- ECTFE (Halar®) coating
- PFA coating
- FEP coating
- PTFE sheet

-> See datasheet "Polymer solutions"

For extended seals there is the option to be executed with a PTFE lining used to prevent the EXT seal is stuck in the nozzle due to clogging or crystallisation of process media. The lining is on all sides minimum of 1mm thickness

Capillary tube and armor (protection)

The standard capillary mounting position is top side (axial) of the seal. Alternatively, the capillary can be placed at the side of the seal (radial). The standard tube material is TP316 (316SS), optionally available in Alloy 400. There are three options in ID of the capillary; 2mm, 1mm, and 0.7mm. Badotherm capillaries are always protected against mechanical forces by armor. This doubled shielded armor consist is standard AISI 304, and optionally AISI 316. Additionally, the armor could be protected with a PVC sleeve in white, black, optionally with ATEX114 approval to protect against dust and water ingress and possibly corrosive ambient atmosphere.

-> See datasheet "Capillary lines"

Jacket holes & Tapered extension

In some cases extended seals get stuck in the nozzle by the crystalized or hardened surrounding process media. There are two option that can be selected to make removal easier. A tapered extension from tip to flange and jacket holes. Jacket holes can be added to the flange for easy removal of extended seals. Standard sizes for jacket holes are ANSI B1.1 5/8" UNC for ASME flanges and ISO 724 M16x1.5 for EN flanges. The tapered version is reducing the diameter 0.7mm/100mm of extension length.

Cooling options

There are several ways to protect the instrument from elevated temperatures, such as the extended direct mount (EDM), a temperature reducer (TR) or by means of capillary.

-> See datasheet "cooling devices"

Lifting handles

Larger sizes and ratings of diaphragm seals can weigh up to 50 kg. Handling and installation can become a challenge. As from 15kg it is recommended to apply a set of lifting handles, welded on the sides of the flange of the seal. This can be used to handle it easier and install it in a safer way or have attach lifting tools to it.

-> See datasheet "diaphragm seal accessories"

Material Certification

Material traceability and related certification are applicable for all process wetted parts. Material certification possibilities depend on the type of seal, the assembly construction and the materials used. Material certification is in accordance with EN10204 3.1.

Additional material certification and testing can be provided on request, such as Positive Material Identification (PMI), Intergranular corrosion (IGC) testing, material certification in accordance with EN10204 3.2, NACE conformity for ISO-15156 (MR-0175) and/or ISO-17945 (MR-0103), NORSOK M-630 and many more.

-> Please note that the responsibility for material selection always rests with the user.

Flange Marking & Traceability

All flanges are marked by the forging shop with heat number, material designation, size, and rating. Badotherm adds a Badotherm reference number and the manufacturers name to the flange for traceability purposes.

Flanges and origin

The seal parts are made from forged materials according to the applicable standards. The standard sourcing of flanges is of international origin. Optionally regional preference can be requested, for example materials from EU origin.

Testing

All seals are helium tested according to the ISO 20485 test procedure A.3 up to 10^{-9} mbar l/s before used on a diaphragm seal application.

-> See datasheet "Diaphragm Seal testing"

Cleanliness of the wetted parts

All parts are standard cleaned from excessive oil and grease. When additional requirements are needed, the parts can be cleaned according customer requirements and cleaning specifications.

Gaskets

Sizes of the diaphragm area are designed to match the gaskets used between the process and seal or flush ring. For the ASME B16.5 RF flanges the ASME B16.20 is used for dimension restriction to ensure both the spiral and grooved gaskets are fully supported by the serrated area. For the EN type B1 flanges the gasket dimensions are matching the sizes of the EN 1514-2. The size "G" in the tables refer to the start of the gasket surface.

Example performance calculation

Whether a diaphragm seal can be used for a specific measurement, depends on the size of the diaphragm. That size is restricted by the size of the diaphragm seal.

For pressure transmitters, Badotherm offers an online performance calculation tool to calculate its performance and to ensure that the diaphragm size is suitable for your measurement.

The table below presents the minimum span of the respective diaphragm sizes with standard process conditions. As rule of thumb, a TPE of max 5% is often considered acceptable, but it depends per situation.

Minimum span table

dD	AP/GP	DP
32mm	11 bar	1850 mbar
44mm	1575 mbar	255 mbar
72mm	155 mbar	30 mbar
81mm	110 mbar	20 mbar

Pressure transmitter; ambient temperature -10...+30°C; process temperature 100°C with BSO 22 fill fluid; 3 meter capillary; ID 1mm, DP both sides mounted with seal

See the general overview of all diaphragm sizes with several standard situations and in combination with Badotherm pressure gauges.

Roughness conversion

The specific flange norm all relate to specific roughness value for surface finish and flange finish. Below table can be used for conversion between the average roughness (Ra) in micrometres (µm) and microinch (µin)

µm	µin
0.8	32
1.6	63
3.2	125
6.3	250

Extension length and diameter

Length and diameter can be selected in random dimensions. In the dimension tables the standard diameters are given, however variation can be made upon request. The length of the extension is always customer selected. Most common length of extensions are 50mm, 100mm, and 150mm.

Heavy duty execution

The normal extended seal is made from a blind flange, tube and a tip made from bar. For higher pressures, non-standard diameters and exotic materials the extension are made from solid bar stock material. The positive effect is that the extension can withstand higher loads. The negative influence is that the extensions has more weight compared to the tube version. The weight can be calculated according to the rule mentioned in the dimension table.

Standards used

Design Standards

Standard	Description
ASME B16.5 - 2020	Pipe flanges and flanged fittings
ASME B16.20 - 2017	Metallic gaskets for flanges
EN 1092-1 - 2018	Circular flanges for pipes
EN 1514-2 - 2021	Dimensions of gaskets
API ISO 10423 (API 6A) - 2010	International Standard for Petroleum and Natural Gas Industries
JIS B2220 - 2012	Japanese Flange Standard
GOST 33259 - 2015	Russian Flange Standard

Test Standards

Standard	Description
ISO 20485 - 2018	Non-destructive testing - Leak testing - Tracer gas method

Material Standards

Standard	Description
NACE MR0175/MR0103 ISO 15156 - 2020	use in H ₂ S-containing environments in oil and gas production
NORSOK M-630 - 2010	specification for use in pipelines
ASTM standards	Material specific standards

Certification Standards

Standard	Description
EN 10204 - 2017	Inspection documents
ASME IX	Welding, Brazing, and Fusing Qualifications
ISO 15610	Specification and qualification of welding procedures for metallic materials

Dimensions table: ASME 16.5 RF facing

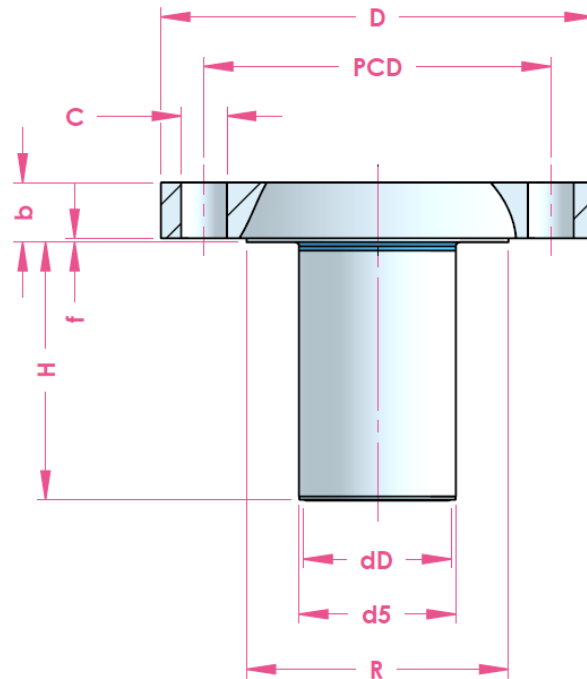

size	rating	D	b	PCD	C / pcs	dD	d5	R	F	weight	EXT weight ¹	
1.5"	cl. 150	127.0	17.9	98.6	15.9 / 4x	32.0	38.0	73.0	1.5	1.5	+ 0.09 x H*	
	cl. 300	155.0	21.1	114.3	22.3 / 4x				2.7			
	cl. 400-600		29.3						3.3			
	cl. 900-1500		38.8						5.8			
	cl. 2500	178.0	38.8	124.0	28.6 / 4x				6.4	10.4		
2"	cl. 150	152.0	19.5	120.6	19.1 / 4x	44.0	48.0	91.9	1.5	2.4	+ 0.004 x H	
	cl. 300	165.0	22.7	127.0	19.1 / 8x				3.2			
	cl. 400-600		32.4						4.2			
	cl. 900-1500		45.1						10.1			
	cl. 2500	216.0	57.9	171.4	28.6 / 8x				6.4	15.6		+ 0.014 x H*
3"	cl. 150	190.0	24.3	152.4	19.1 / 4x	72.0	76.0	127.0	1.5	4.9	+ 0.010 x H	
	cl. 300	210.0	29.0	168.1	22.3 / 8x				6.8			
	cl. 400-600		38.8						8.4			
	cl. 900		45.1						13.1			
	cl. 1500	267.0	54.7	203.2	31.9 / 8x				6.4	19.1		+ 0.035 x H*
	cl. 2500	305.0	73.7	228.6	35.0 / 8x				34.8			
4"	cl. 150	229.0	24.3	190.5	19.1 / 8x	81.0	93.0	157.2	1.5	7.0	+ 0.029 x H	
	cl. 300	254.0	32.2	200.2	22.3 / 8x				11.5			
	cl. 400		42.0						14.8			
	cl. 600		45.1						17.3			
	cl. 900	273.0	51.5	235.0	31.8 / 8x				6.4	26.9		+ 0.055x H*
	cl. 1500	311.0	61.0	241.3	34.9 / 8x				29.9			
	cl. 2500	356.0	83.2	273.0	41.3 / 8x				53.9			

All dimensions in mm, weight in kg

1) Weights marked with * are based on bar stock material. This weight should be taken for exotics as well.

Dimensions table: EN 1092-1 B1 type

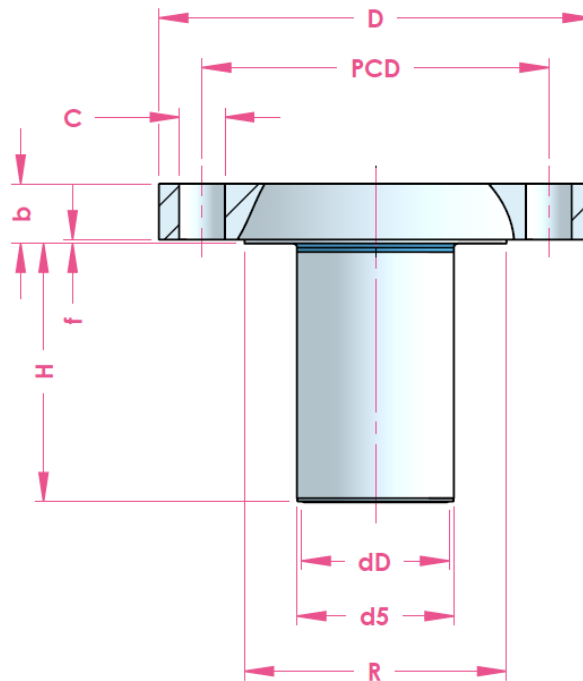

size	rating	D	b	PCD	C / pcs	dD	d5	R	f	Weight	EXT weight ¹
DN40	PN10-40	150.0	18.0	110.0	18.0 / 4x	32.0	38.0	88.0	3.0	2.0	+ 0.09 x H
	PN63-100	170.0	26.0	125.0	22.0 / 4x					4.0	
	PN160		28.0							4.4	
	PN250	185.0	34.0	135.0	26.0 / 4x					6.7	
	PN320	195.0	38.0	145.0						8.7	
PN400	220.0	48.0	165.0	30.0 / 4x	14.1						
DN50	PN10-40	165.0	20.0	125.0	18.0 / 4x	44.0	48.0	102.0	3.0	3.0	+ 0.004 x H
	PN63	180.0	26.0	135.0	22.0 / 4x					4.5	
	PN100	195.0	28.0	145.0	26.0 / 4x					6.0	
	PN160		30.0							6.4	
	PN250	200.0	38.0	150.0	26.0 / 8x					8.2	
	PN320	210.0	42.0	160.0						10.7	
	PN400	235.0	52.0	180.0	30.0 / 8x					16.7	
DN80	PN10-40	215.0	24.0	160.0	18.0 / 8x	72.0	76.0	138.0	3.0	5.0	+ 0.010 x H
	PN63	230.0	28.0	170.0	22.0 / 8x					6.5	
	PN100		32.0	180.0	26.0 / 8x					9.0	
	PN160	36.0	180.0	26.0 / 8x	10.3						
	PN250	255.0	46.0	200.0	30.0 / 8x					16.5	
	PN320	275.0	55.0	220.0						25.4	
	PN400	305.0	68.0	240.0	33.0 / 8x					38.4	
DN100	PN10-16	220.0	20.0	180.0	18.0 / 8x	81.0	93.0	158.0	3.0	4.5	+ 0.029 x H
	PN25-40	235.0	24.0	190.0	22.0 / 8x			6.5			
	PN63	250.0	30.0	200.0	26.0 / 8x			9.0			
	PN100	265.0	36.0	210.0	30.0 / 8x			13.0			
	PN160		40.0					15.3			
	PN250	300.0	54.0	235.0	33.0 / 8x			27.2			
	PN320	335.0	65.0	265.0	36.0 / 8x			42.5			
	PN400	370.0	80.0	295.0	39.0 / 8x			67.3			
										162.0	+ 0.055x H

All dimensions in mm, weight in kg

1) Weights marked with * are based on bar stock material. This weight should be taken for exotics as well.

Dimensions table: additional dimensions for options tapered and lining

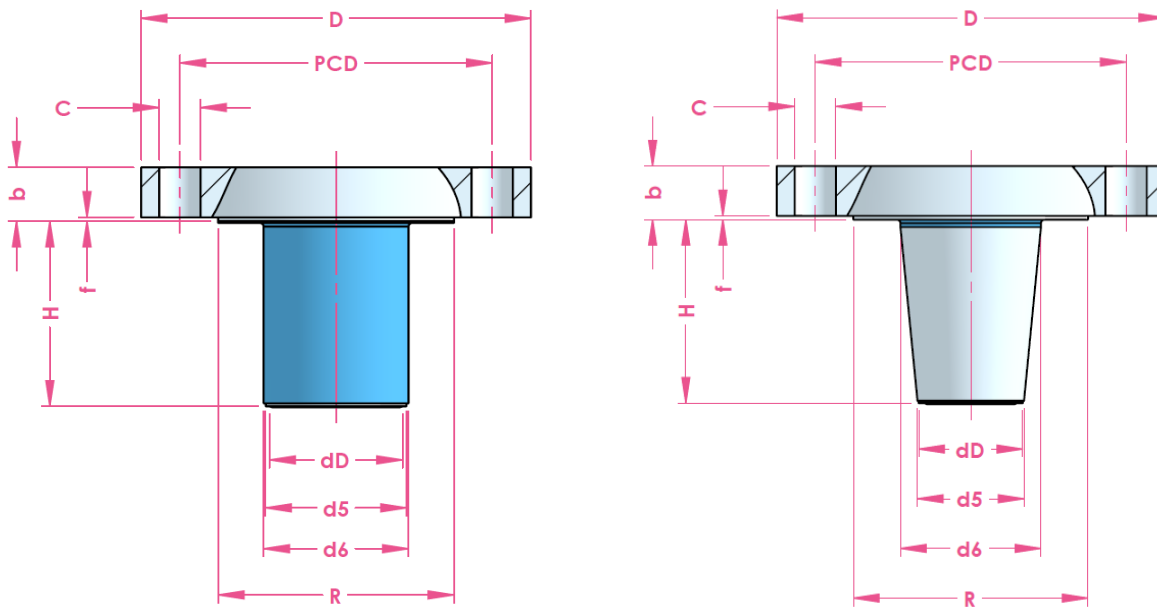

Lining

d5	d6	dD	D	b	PCD	C / pcs	dD	d5	R	f
d5 + 4.0	Customer defined	See note	See standard dimension tables for sizing							

- 1) The size d6 can be defined by the end user.
- 2) The diaphragm diameter depends on the selected size d6. The goal is to execute the EXT with the largest diaphragm possible.

Tapered

d5	D6	dD	D	b	PCD	C / pcs	dD	d5	R	f
standard	d5 + 0.7mm/100mm	See standard dimension tables for sizing								

- 1) The size d5 can be defined by the end user.

Change log

Date	Change
31-8-2020	Added drawings for lining and tapered execution
	All ASME dimension tables updated according ASME B16.5:2020
8-3-2021	Added a standard reference table to the datasheet.
	Added a roughness conversion table

Holland – Romania – India – Thailand – Dubai – USA

To our knowledge, the information contained herein is accurate as of the date of this document. However neither Badotherm, nor its affiliates makes any warranty, express or limited, or accepts any liability in connection with this information or its use. This information is for technical skilled persons at their own discretion and risk and does not relate to the use of this product in combination with any other product. The user alone finally determines suitability of any information or material in contemplated use, the manner of use and whether any patents are infringed. This information gives typical properties only. Badotherm reserves the right to make changes to the specifications any materials without prior notice. The latest version of the datasheet can be found on www.badotherm.com.

© 2015 Badotherm, all rights reserved. Trademarks and/or other products referenced herein are either trademarks or registered trademarks of Badotherm.